

C Boring Head

59200 BHC2 Boring Head



Features:

- ▶ Inch/Metric graduation, min. 0.0005" / 0.01mm.
- ▶ Adjustable feed 15mm (5/8")
- ▶ Inch/Metric standard is available.

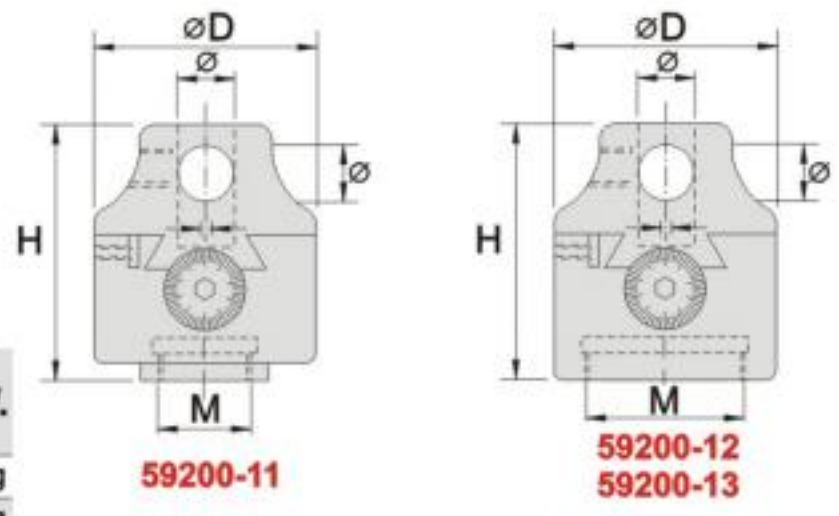

Order No.	Model	D	H	Boring Bar Hole Dia.	Center Dist. Btw holes	Feed	M	N.W.
59200-11	BHC2 inch	2"Dia	2-7/16"	1/2"	5/8"	5/8"	7/8"-20	0.7kg
59200-12	BHC2 m/m	Ø50	63	12	15	15	1-1/2-18"	0.7kg
59200-13	BHC2 inch	2"Dia	2-7/16"	1/2"	5/8"	5/8"	1-1/2-18"	0.7kg

59200A BHC2 Boring Head+Shank

Order No.	Model	Spec.	N.W.
59200A-02	BHC2+BT40	M16xP2.0	2.0kg
59200A-04	BHC2+BT50	M24xP3.0	4.7kg
59200A-06	BHC2+R8	7/16"x20UNC	1.3kg
59200A-08	BHC2+NT30	1/2"x12UNC	1.3kg
59200A-10	BHC2+NT30	M12xP1.75	1.3kg
59200A-12	BHC2+NT40	5/8"x11UNC	2.0kg
59200A-14	BHC2+NT40	M16xP2.0	2.0kg
59200A-16	BHC2+NT50	1"x8UNC	3.9kg
59200A-18	BHC2+NT50	M24xP3.0	3.9kg
59200A-20	BHC2+MT2	3/8"x16UNC	1.0kg
59200A-22	BHC2+MT2	M10xP1.5	1.0kg
59200A-24	BHC2+MT3	3/8"x16UNC	1.2kg
59200A-26	BHC2+MT3	1/2"x13UNC	1.2kg
59200A-28	BHC2+MT3	1/2"x12UNC	1.2kg
59200A-30	BHC2+MT3	M12xP1.75	1.2kg
59200A-32	BHC2+MT4	5/8"x11UNC	1.6kg
59200A-34	BHC2+MT4	M16xP2.0	1.6kg
59200A-36	BHC2+MT5	1"x8UNC	2.1kg
59200A-38	BHC2+MT5	M24xP3.0	2.1kg
59200A-40	BHC2+MT2	TANGED	1.1kg
59200A-42	BHC2+MT3	TANGED	1.2kg
59200A-44	BHC2+MT4	TANGED	1.5kg
59200A-46	BHC2+MT5	TANGED	2.6kg



Straight Shank

Order No.	Model	Spec.	N.W.
59200A-48	BHC2+ Ø20	Ø20x60L	1.1kg
59200A-50	BHC2+ Ø25	Ø25x60L	1.2kg
59200A-52	BHC2+ Ø32	Ø32x60L	1.4kg

BORING HEAD