

52960

VSD

Tool Maker Vise



Material	Tool Steel
Hardness	HRC52°~58°
Parallelism	within 0.004mm/100mm
Squareness	within 0.006mm/100mm

Features :

- ▶ New structure design for minimum clearance occurred when lock tight also handle with hex hole can apply hex wrench to lock tighter. Simple dismantle the screw bar when worn.

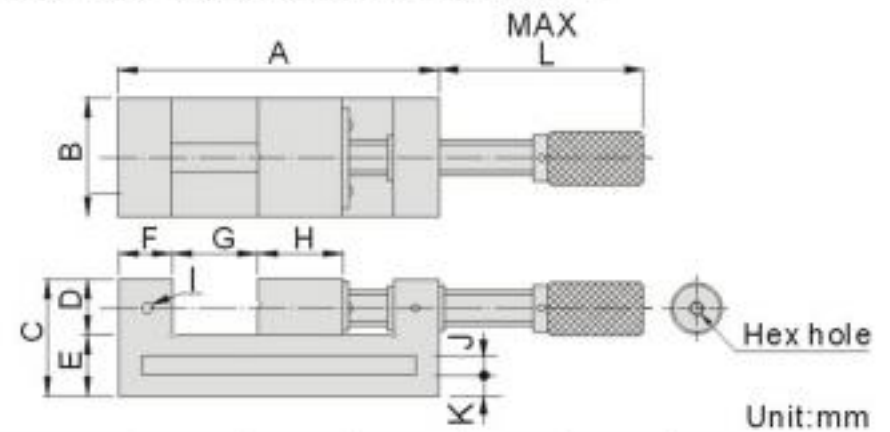

Order No.	Model	A	B	C	D	E	F	G	H	I	J	K	L	N.W.
52960-20	VSD20	156	48	52	25	27	25	0-63	34	M6	8	9.5	125	2.3kg
52960-25	VSD25	176	63	63	30	33	30	0-73	40	M6	10	11.5	147	4.0kg
52960-30	VSD30	190	73	73	35	38	35	0-76	45	M6	10	14	151	5.5kg
52960-40	VSD40	255	98	82	40	42	40	0-120	50	M8	12	15	196	11.0kg
52960-50	VSD50	310	125	100	50	50	50	0-152	57	M8	14	18	231	18.3kg
52960-60	VSD60	325	150	100	50	50	50	0-165	60	M8	14	18	245	20.0kg
52960-80	VSD80	350	200	110	55	55	45	0-195	70	M10	16	19.5	281	34.5kg

TOOL MAKER VISE

52970

PGV

Precision Hydraulic Vise



Features :

- ▶ Adopting hydraulic structure with stronger clamping force.
- ▶ High precision and quality, popular in worldwide.

Material	Tool Steel
Hardness	HRC52°~58°
Max clamping force	1500kgf
Parallelism	within 0.005mm/100mm
Squareness	within 0.008mm/100mm

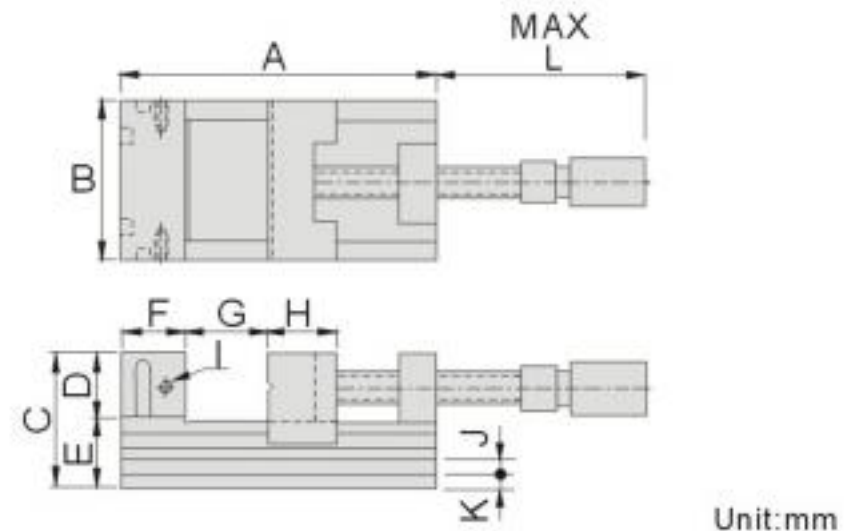
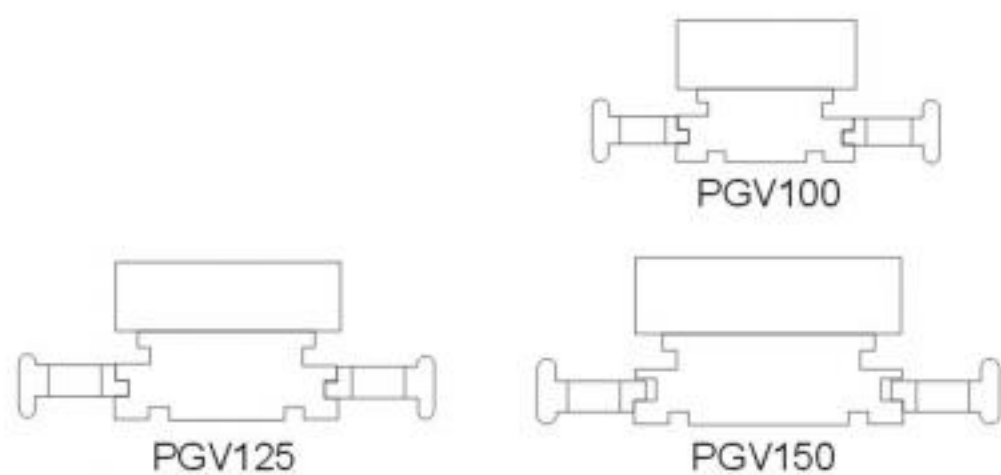

Order No.	Model	A	B	C	D	E	F	G	H	I	J (WxD)	K	L	N.W.
52970-100	PGV100	220	100	80	40	40	40	110	50	M10	9x7	9.5	235	11.1kg
52970-125	PGV125	300	125	90	40	50	60	165	70	M10	11x7	12.5	290	20.6kg
52970-150	PGV150	340	150	95	45	50	60	210	70	M10	12x11	14	340	23.5kg